

DENAFRIPS

IRIS DDC

OWNER'S MANUAL

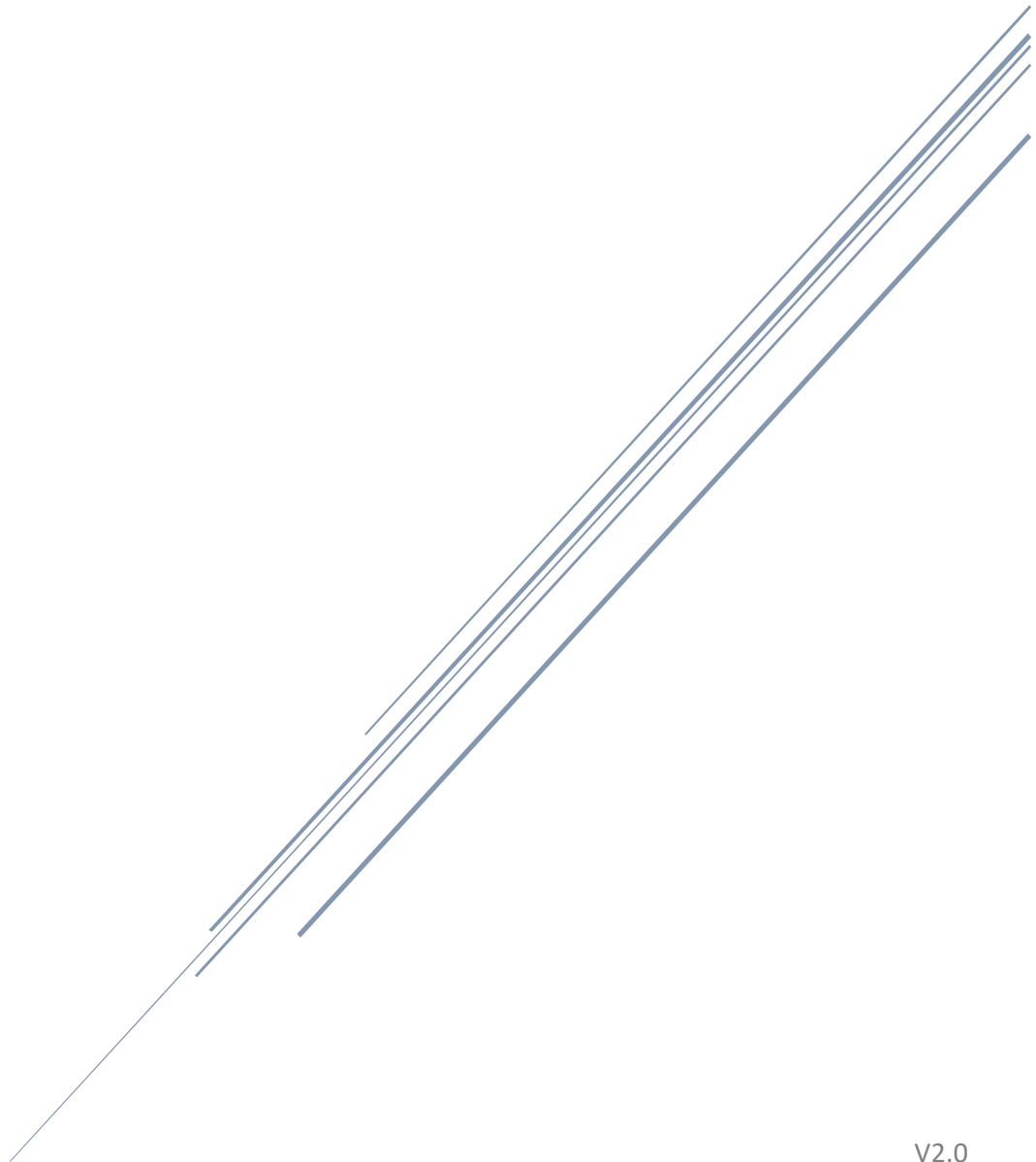

V2.0
20th June 2021

Contents

1. INSTALLATION & SAFETY INSTRUCTIONS	2
2. INTRODUCTION	3
3. DESIGN HIGHLIGHTS	4
3.1 DIGITAL ISOLATION	4
3.2 FEMTO CRYSTAL OSCILLATOR	4
3.3 ADAPTIVE FIFO BUFFER RECLOCKING	4
3.4 PROPRIETARY, STATE-OF-THE-ART USB INTERFACE	5
3.5 DDC ARCHITECTURE	5
3.6 CLOCK IN.....	5
4. OPERATING INSTRUCTION.....	6
4.1 Quick Start Guide	6
4.2 USB DRIVER INSTALLATION – WINDOWS OS.....	11
5. SPECIFICATIONS.....	15
6. WARRANTY	16

1. INSTALLATION & SAFETY INSTRUCTIONS

This DDC is designed and built to provide trouble-free performance, but as with all electronic devices it is necessary to observe a few precautions:

- Unpack the DDC carefully.
- Position the DDC on a stable, horizontal surface, i.e. sturdy rack.
- The DDC supports 100/250VAC mains voltage. Please check the voltage switch underneath the DDC, switch it to the correct voltage before connecting the AC mains. Please connect the AC power cord with earth(ground) pin unless it is absolutely required to reduce hum from the ground loops of the connected devices.
- Always ensure that when disconnecting and reconnecting your audio equipment the mains supply is turned off.
- Position the power cord and signal interconnects where they are not likely cause trip and fall hazard.
- Do not use the DDC near water, or place water-filled containers on the DDC. Entry of liquid into the DDC is hazardous and may cause electric shock and/or fire hazard.
- Do not place the unit under direct sunlight or heat source.
- Do not remove any covers or try to gain access to the inside. There are no user adjustments or fuses to change without qualification.
- Clean regularly with a damp soft cloth. Do not use any cleaning agents as it might damage the surface finishing.
- The electronics in modern hi-fi equipment is complex and may, therefore, be adversely affected or damaged by lightning. For protection of the audio system during electrical storms, disconnect the mains plugs.

2. INTRODUCTION

Thank you for purchasing the DENAFRIPS IRIS DDC.

The entry DDC, built upon the success of the DENAFRIPS Digital Know-How. IRIS DDC isolates and buffers the USB input data, re-clock them via the local FEMTO Crystal Oscillators. The cleansed, ultra-low jitters digital output can be connected to any external DAC.

It transforms the Computer Audio System into a high-quality transport. The sonic improvement is evident as soon as the IRIS DDC is added into the Digital Audio chain.



3. DESIGN HIGHLIGHTS

3.1 DIGITAL ISOLATION

The IRIS Digital Signals are completely isolated by the 50-Mbps high speed photocouplers. The optical isolation yields even lowered noise-floor and achieved high signal to noise ratio.

3.2 FEMTO CRYSTAL OSCILLATOR

The IRIS is equipped with dual FEMTO Clocks operating at audio frequencies 45.1584Mhz, 49.152Mhz. The dual FEMTO Clocks are powered by the o-core transformer, multi-stages linear regulators. The clean linear power supply ensures superior stability and linearity of the FEMTO Clocks output frequency.

3.3 ADAPTIVE FIFO BUFFER RECLOCKING

The DENAFRIPS approach to address the jitters issue by FIFO BUFFER RECLOCKING. The adaptive FIFO buffer store the source digital audio data in the memory. These data are read from the memory using the FEMTO CLOCK, located right in the DDC.

3.4 PROPRIETARY, STATE-OF-THE-ART USB INTERFACE

The IRIS is equipped with the proprietary USB Audio Solution, powered by STM32F446 Advanced AMR Based MCU. DENAFRIPS redesigned and optimized circuitry, allow the DDC to be used as high-end DDC with computers / streamers. It supports 24bit/768kHz PCM data stream, and native processing of DSD up to DSD1024. It comes with licensed THESYCON USB Driver for Windows Platform.

NOTE: The USB Module is designed to trigger on *only* when USB Input is selected. This is intended design to reduce digital input interfaces cross-interference for best sound reproduction.

3.5 DDC ARCHITECTURE

DIGITAL SIGNAL PROCESSING – All digital input data are stored in the on-board FPGA high-speed RAM.

FEMTO CLOCKS – These data are read from the memory using the ultra-low phase noise, super accurate FEMTO CLOCKS, located right in the DDC. The processed data are sent to the digital outputs.

DIGITAL OUTPUTS – The cleansed, ultra-low jitters data are output via multiple digital output interfaces simultaneously to the external DAC.

3.6 CLOCK IN

The IRIS supports clock in of audio frequencies 45.1584Mhz, 49.152Mhz. It makes a perfect companion with the *TERMINATOR II* or *TERMINATOR PLUS* to synchronize the CLOCKS.

4. OPERATING INSTRUCTION

4.1 Quick Start Guide

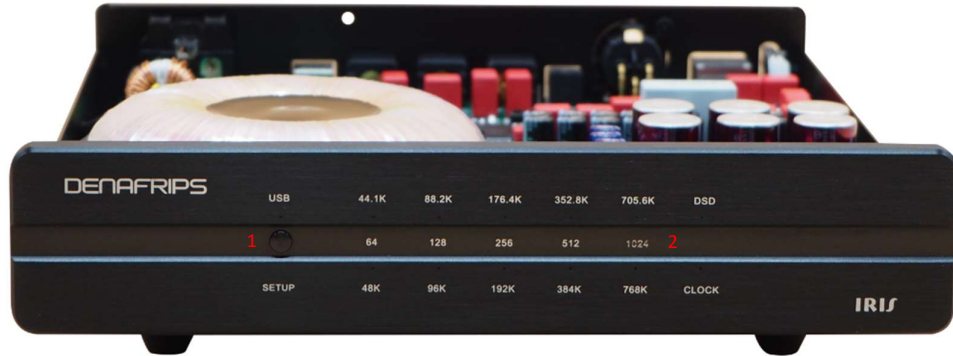

Figure 1. Front Panel

(1) Setup Button

Press the setup button once to enable/disable the CLOCK-IN feature.

- Press Setup button once
- CLOCK light should be on/off as the Setup button is pressed momentarily
- CLOCK light on = Enable clock in
- CLOCK light off = Disable clock in

(2) Digital Audio Signal Input Sampling Rate

The following table illustrate the Input Sampling Rate LED status.

Base Sampling Rate	Indicator	Input Format
44.1 kHz	44.1K	44.1 kHz
	88.2K	88.2 kHz
	176.4K	176.4 kHz
	352.8K	352.8 kHz
	705.6K	705.6 kHz
48 kHz	48K	48 kHz
	96K	96 kHz
	192K	192 kHz
	384K	384 kHz
	768K	768 kHz
DSD	64	DSD 64
	128	DSD 128
	256	DSD 256
	512	DSD 512

Table 1. Sampling Rate



Figure 2. Read Panel

Description:

(1) AC Power Supply

CAUTION! IRIS supports AC mains range from 100-250VAC. Please check the voltage switch underneath the DDC, switch it to the correct voltage before connecting the AC mains.

(2) Digital Input Interface

IRIS support USB input only.

(3) Digital Output Interface

There are 5 Digital Output Interfaces, namely, COAX, AES, OPT, I2S-A, I2S-C. All outputs are active simultaneously.

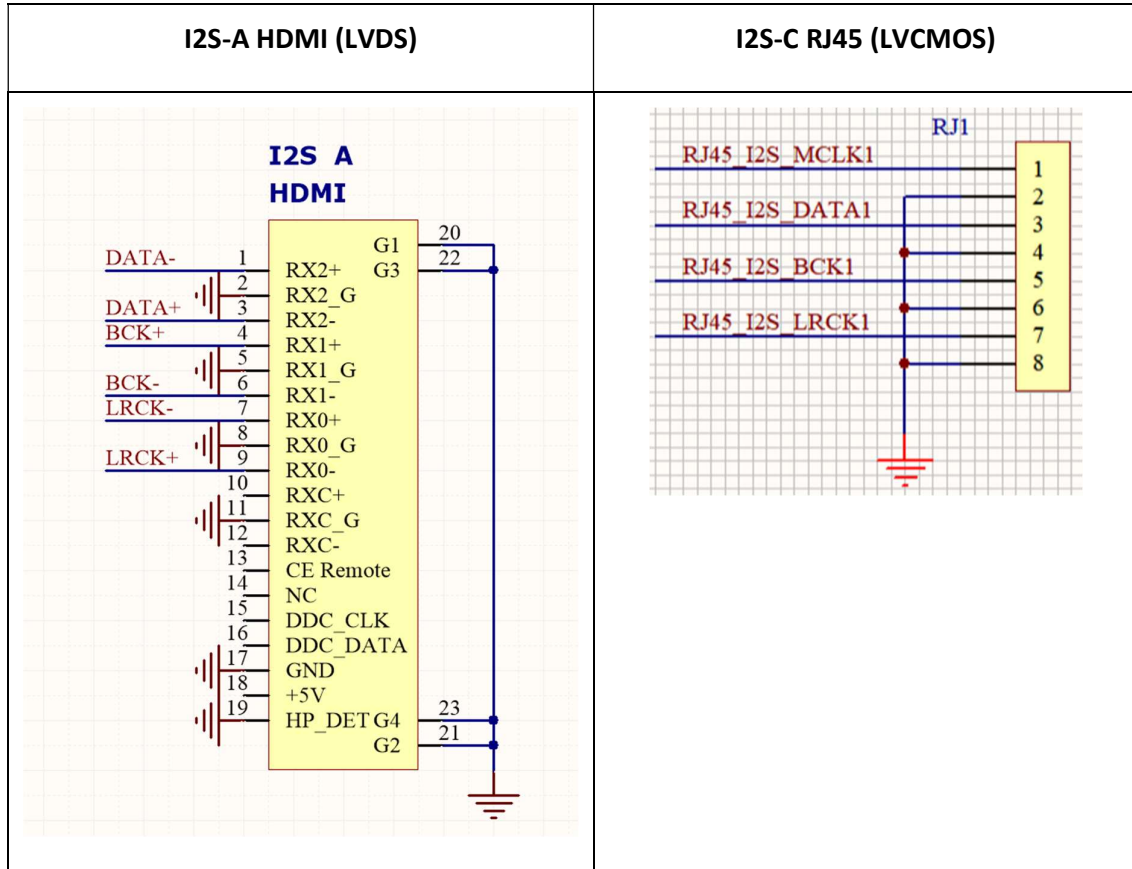

(4) CLOCK IN

The IRIS supports the following clock frequencies input, leveraging the high-quality OCXO of the *TERMINATOR II* or *TERMINATOR PLUS* DAC, it may be connected to IRIS CLOCK-IN to improve the sonic performance.

MASTER CLOCK

- 45.1548MHz, 49.152Mhz

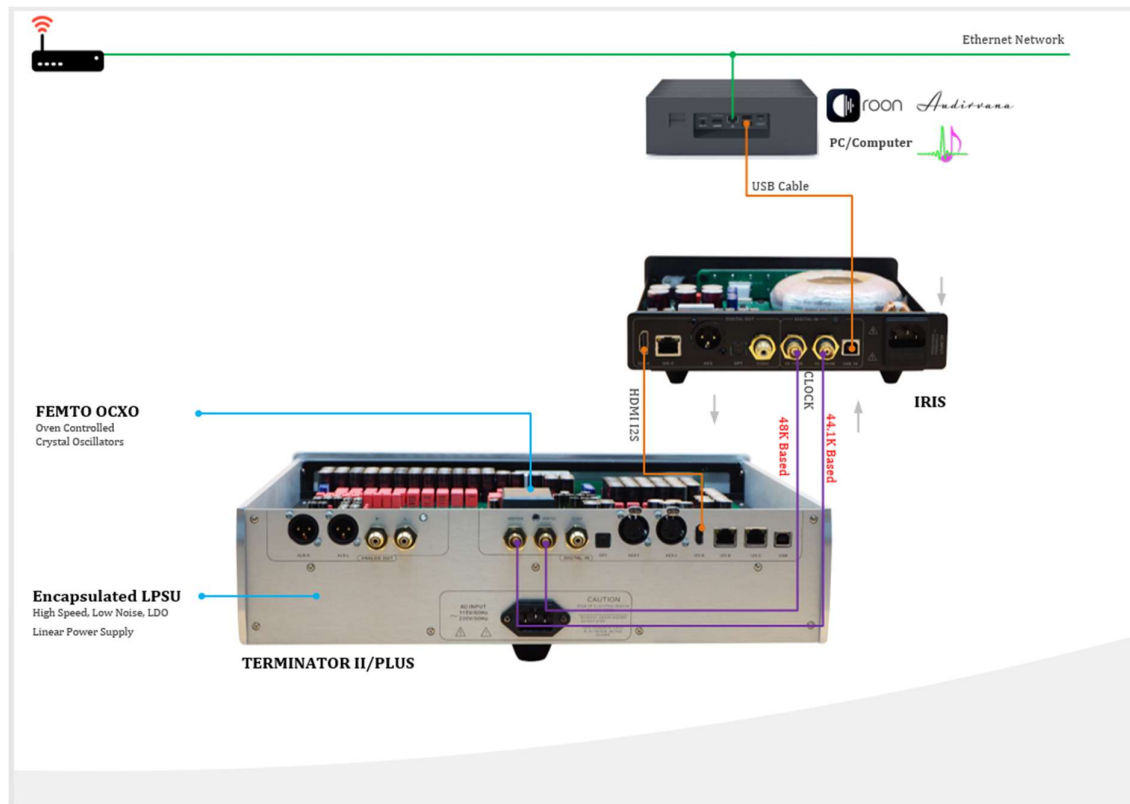

4.2 USB DRIVER INSTALLATION – WINDOWS OS

USB driver is required for Windows Operating System (Windows 7/8/8.1/10, X86/X64). The USB driver is licensed by THESYCON to provide the highest quality audio playback for Computer Audio System.

NOTE: Mac and Linux OS do not require the USB driver.

Installation Guide:

- Download the driver from the support page: <https://www.denafrips.com/support>
- Do not connect the USB cable from the computer to the DDC. Remove it before the USB driver installation
- Double click the “DENAFRIPS_UsbAudio_v4.82.0” (or the latest version) to install the USB driver.
- Follow the on-screen instruction to complete the installation

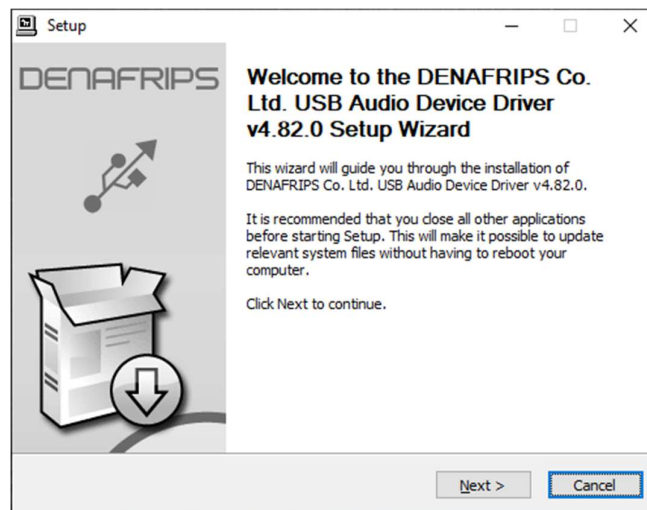

Figure 3. Welcome screen

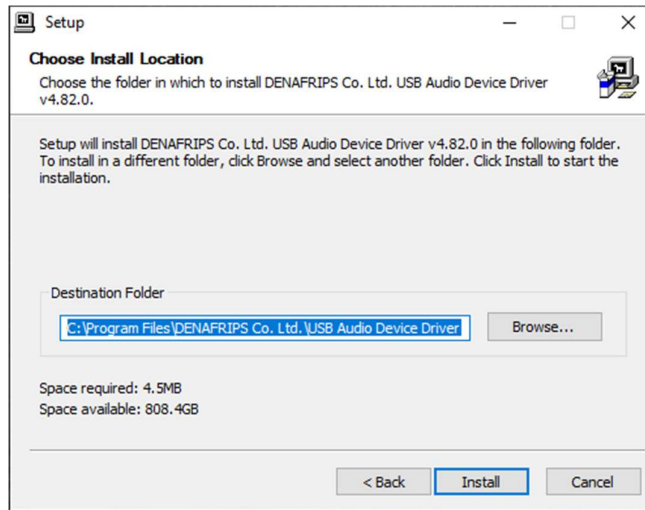

Figure 4. Default Installation Directory

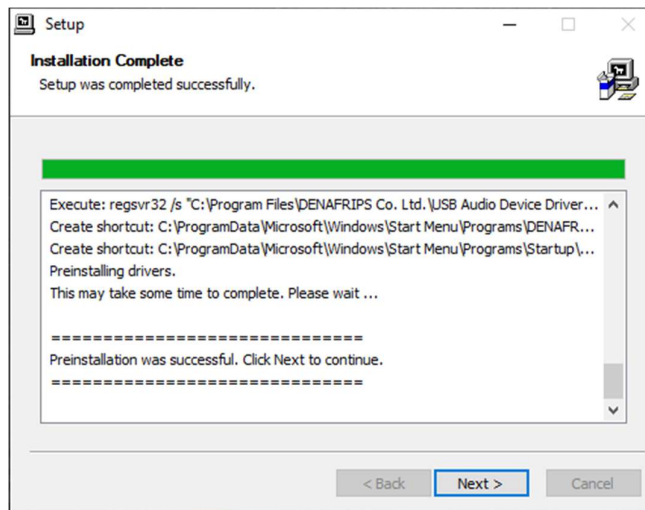

Figure 5. Preinstallation Successful

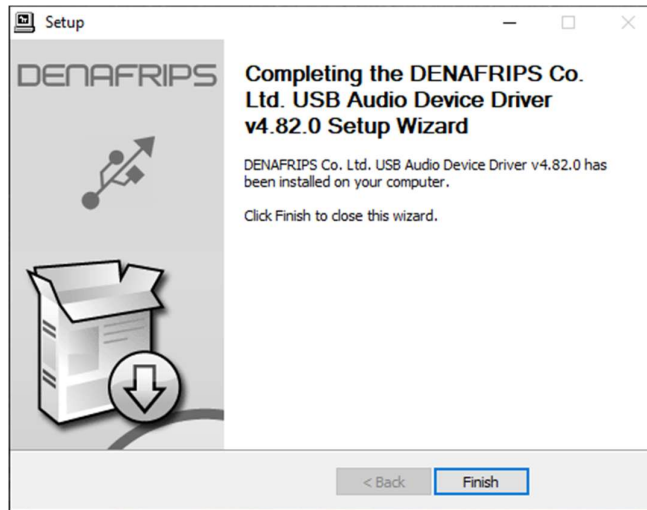

Figure 6. Completed

- Restart the computer to complete the installation
- Connect the USB cable to the DDC
- Power on the DDC.
- The USB DDC shall be detected. The driver status can be monitored as follows

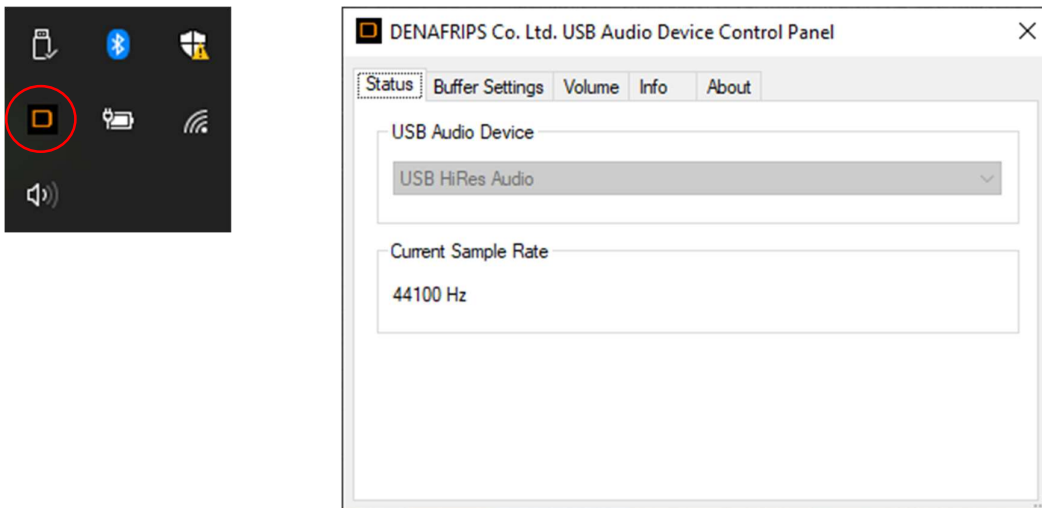
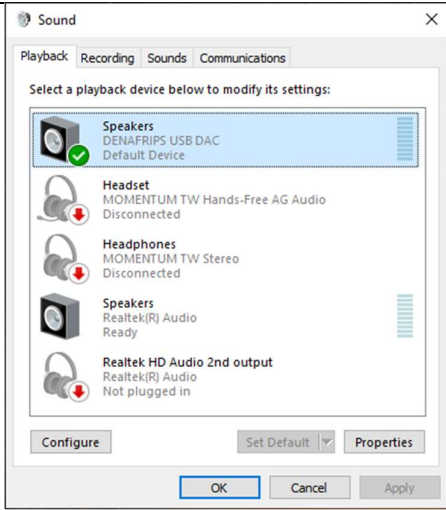
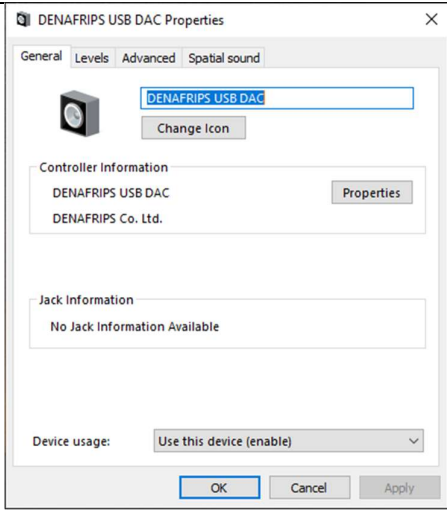
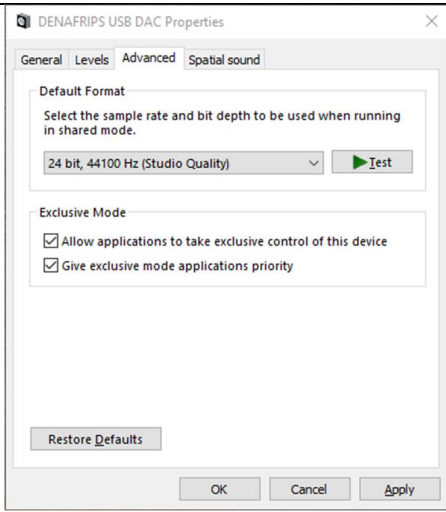
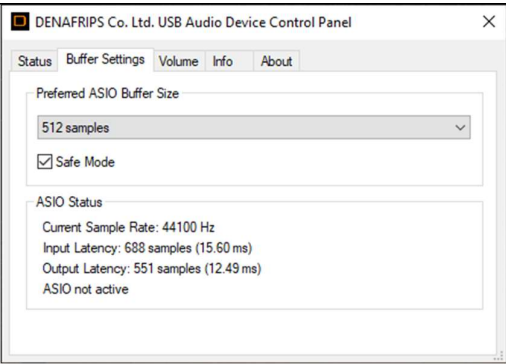

Figure 7. Taskbar & Control Panel

- Select DENAFRIPS USB DDC as default Windows OS Soundcard

	
<p>Press Set Default button</p>	<p>Properties of the DENAFRIPS USB DDC</p>
	
<p>Direct-Sound default format</p>	<p>ASIO Buffer Size</p>

Playback software recommendation:

- roon
- JRiver
- Foobar2000
- Sonicstudio Amarra
- Audirvana / Audirvana Studio

5. SPECIFICATIONS

Description	Parameters
AC Power	110VAC or 240VAC
Power Consumption	< 20W
Digital Input	USB
External Clock Input	45.1584MHz 49.152Mhz
Digital Output	Coax SPDIF via RCA TOSLink x 1 AES/EBU x 1 I ² S HDMI LVDS Standard I ² S RJ45 LVCMOS Standard
Supported Format (DSD)	DSD64 All Input DSD64 – DSD512 USB & I ² S Only
Supported Format (PCM)	24bit/44.1, 48, 88.2, 96, 176.4, 192 kHz All Input 44.1 – 768 kHz on USB & 44.1 – 384kHz on I ² S Only
Dimension	220W x 250D x 44H mm (Feet +18mm)
Weight	3.5 Kg

6. WARRANTY

DENAFRIPS IRIS purchased from the Authorized Distributor comes with 36 months of warranty from the date of purchase / delivery (whichever later).

Defective Within	Warranty Policy
First 30 Days	DENAFRIPS to bear both way shipping fee.
Within 1st Year	Customer to bear one-way shipping fee. DENAFRIPS shall cover the return shipping fee.
Within Warranty Period	Customer to bear both way shipping fee. DENAFRIPS to repair at free of charge.
Out of Warranty	Customer to bear both way shipping cost. DENAFRIPS to provide repair / maintenance services at cost.